

This is a sample of an uncapitalized title of a thesis submitted to Iowa State University that  
continues on a second line: The word after a colon is usually capitalized

by

Joseph Graduate Student

A thesis submitted to the graduate faculty  
in partial fulfillment of the requirements for the degree of  
MASTER OF SCIENCE

Major: Human Development and Family Studies (Marriage and Family Therapy)

Program of Study Committee:  
Jeffrey L. Balvanz, Major Professor  
Joseph A. Struss  
Alan G. Vetter

Iowa State University

Ames, Iowa

2009

Copyright © Joseph Graduate Student, 2009. All rights reserved.

**TABLE OF CONTENTS**

LIST OF FIGURES	iii
LIST OF TABLES	iv
ABSTRACT	v
CHAPTER 1. OVERVIEW	1
Introduction	1
First Hypothesis	1
Second Hypothesis	1
Criteria Review	2
CHAPTER 2. REVIEW OF LITERATURE	3
Introduction	3
First Hypothesis	3
Second Hypothesis	3
Criteria Review	4
CHAPTER 3. METHODS AND PROCEDURES	5
Introduction	5
First Hypothesis	5
Second Hypothesis	6
Criteria Review	7
CHAPTER 4. RESULTS	8
Introduction	8
First Hypothesis	8
Second Hypothesis	9
Criteria Review	9
CHAPTER 5. SUMMARY AND DISCUSSION	10
Introduction	10
First Hypothesis	10
Second Hypothesis	12
Criteria Review	12
APPENDIX A. ADDITIONAL MATERIAL	13
APPENDIX B. STATISTICAL RESULTS	17
BIBLIOGRAPHY	18
ACKNOWLEDGEMENTS	19

## LIST OF FIGURES

Figure 1. Gamma measurements from irradiated samples	6
Figure 2. Example web graphic	8

**LIST OF TABLES**

Table 1. This table shows a standard empty table	5
Table 2. This table shows a standard empty table with a limited caption width using important data from Smith and Watkins (2006)	7
Table 3. Moon data	8
Table 4. This table shows almost nothing but is a sideways table and takes up a whole page by itself	11
Table 5. Software available in the 139 Durham labs in the early 2000s	15
Table 6. Software available in the 139 Durham labs in the early 2000s	16

## ABSTRACT

This is the text of the thesis abstract that will be included as part of the thesis. This page is numbered as a preliminary page; it is not part of the main thesis text, and so must settle for a lower-case Roman numeral for its page number. The heading style is Heading 1, and the text spacing matches the standard main body text. *The inclusion of an abstract as a preliminary page is optional, but an abstract is required at the on-line submission.)*

## **CHAPTER 1. OVERVIEW**

This is the opening paragraph to my thesis which explains in general terms the concepts and hypothesis which will be used in my thesis.

This thesis has more general information than really necessary.

### **Introduction**

Here initial concepts and conditions are explained and several hypotheses are mentioned in brief.

### **First Hypothesis**

Here one particular hypothesis is explained in depth and is examined in the light of current literature.

#### ***Parts of the first hypothesis***

Here one particular part of the hypothesis that is currently being explained is examined and particular elements of that part are given careful scrutiny.

### **Second Hypothesis**

Here one particular hypothesis is explained in depth and is examined in the light of current literature.

***Parts of the second hypothesis***

Here one particular part of the hypothesis that is currently being explained is examined and particular elements of that part are given careful scrutiny.

**Criteria Review**

Here certain criteria are explained thus eventually leading to a foregone conclusion.

## CHAPTER 2. REVIEW OF LITERATURE

This is the opening paragraph to my thesis which explains in general terms the concepts and hypothesis which will be used in my thesis.

This thesis has more general information than really necessary.

### Introduction

Here initial concepts and conditions are explained and several hypotheses are mentioned in brief.

Allen, B. S. (1984), Bruner, J. (1960) and Cox, S. R. (1974) did the initial work in this area. But in Bruner's work [Bruner, J. (1960)] the definitive model is seen.

### First Hypothesis

Here one particular hypothesis is explained in depth and is examined in the light of current literature.

#### *Parts of the first hypothesis*

Here one particular part of the hypothesis that is currently being explained is examined and particular elements of that part are given careful scrutiny.

### Second Hypothesis

Here one particular hypothesis is explained in depth and is examined in the light of current literature.

### *Parts of the second hypothesis*

Here one particular part of the hypothesis that is currently being explained is examined and particular elements of that part are given careful scrutiny.

### **Criteria Review**

Here certain criteria are explained thus eventually leading to a foregone conclusion.

## CHAPTER 3. METHODS AND PROCEDURES

This is the opening paragraph to my thesis which explains in general terms the concepts and hypothesis which will be used in my thesis.

This thesis has more general information than really is necessary.

### Introduction

Here initial concepts and conditions are explained and several hypotheses are mentioned in brief.

As can be seen in Table 1 it is truly obvious what I am saying is true.

**Table 1. This table shows a standard empty table**

---

---

---

---

---

### First Hypothesis

Here one particular hypothesis is explained in depth and is examined in the light of current literature.

This can also be seen in Figure 1 that the rest is obvious.

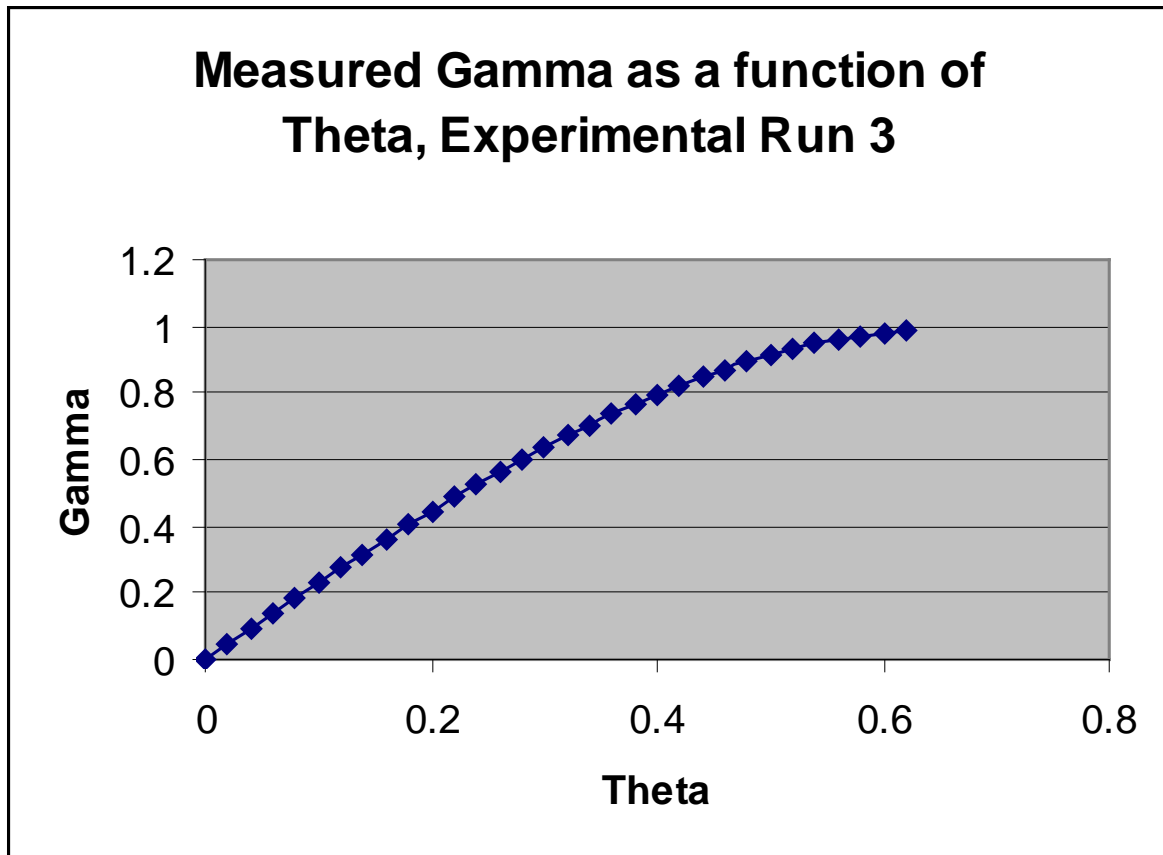

**Figure 1. Gamma measurements from irradiated samples**

### *Parts of the first hypothesis*

Here one particular part of the hypothesis that is currently being explained is examined and particular elements of that part are given careful scrutiny.

### **Second Hypothesis**

Here one particular hypothesis is explained in depth and is examined in the light of current literature.

### *Parts of the second hypothesis*

Here one particular part of the hypothesis that is currently being explained is examined and particular elements of that part are given careful scrutiny.

### **Criteria Review**

Here certain criteria are explained thus eventually leading to a foregone conclusion as can be seen in Table 2.

**Table 2. This table shows a standard empty table with a limited caption width quoting important data from Smith and Watkins (2006)**

---

---

---

## CHAPTER 4. RESULTS

This is the opening paragraph to my thesis which explains in general terms the concepts and hypothesis which will be used in my thesis.

With more general information given here than really necessary.

### Introduction

Here initial concepts and conditions are explained and several hypothesis are mentioned in brief.

Of course, data on this as seen in Table 3 is few and far between.

**Table 3. Moon data**

Element	Control	Experimental
Moon Rings	1.23	3.38
Moon Tides	2.26	3.12
Moon Walk	3.33	9.29

### First Hypothesis

Here one particular hypothesis is explained in depth and is examined in the light of current literature.

Or graphically as seen in Figure 2 it is certain that my hypothesis is true.



**Figure 2. Example web graphic**

***Parts of the first hypothesis***

Here one particular part of the hypothesis that is currently being explained is examined and particular elements of that part are given careful scrutiny.

**Second Hypothesis**

Here one particular hypothesis is explained in depth and is examined in the light of current literature.

***Parts of the second hypothesis***

Here one particular part of the hypothesis that is currently being explained is examined and particular elements of that part are given careful scrutiny.

**Criteria Review**

Here certain criteria are explained thus eventually leading to a foregone conclusion.

## **CHAPTER 5. SUMMARY AND DISCUSSION**

This is the opening paragraph to my thesis which explains in general terms the concepts and hypothesis which will be used in my thesis.

With more general information given here than really necessary.

### **Introduction**

Here initial concepts and conditions are explained and several hypotheses are mentioned in brief.

Or graphically as seen in Figure 5.1 it is certain that my hypothesis is true.

### **First Hypothesis**

Here one particular hypothesis is explained in depth and is examined in the light of current literature.

As can be seen in Table 4 it is truly obvious what I am saying is true.

**Table 4. This table shows almost nothing but is a sideways table and takes up a whole page by itself**

Element	Control	Experimental
Moon Rings	1.23	3.38
Moon Tides	2.26	3.12
Moon Walk	3.33	9.29

*Parts of the first hypothesis*

Here one particular part of the hypothesis that is currently being explained is examined and particular elements of that part are given careful scrutiny.

**Second Hypothesis**

Here one particular hypothesis is explained in depth and is examined in the light of current literature.

*Parts of the second hypothesis*

Here one particular part of the hypothesis that is currently being explained is examined and particular elements of that part are given careful scrutiny.

**Criteria Review**

Here certain criteria are explained thus eventually leading to a foregone conclusion.

## **APPENDIX A. ADDITIONAL MATERIAL**

An appendix is used for materials that do not pertain directly to, but are relevant to the main text. Examples include survey instruments, additional data, computer printouts, details of a procedure or analysis, or a relevant research paper. The material in an appendix may appear in a different font, font size, or use different spacing from the main text of the thesis. You may use smaller margins (but it looks better if you can match the margins of the rest of the text) and the page number must use the same font and position. Use photo reduction if necessary.

If there is only one appendix in your thesis, it should not be numbered or lettered; it should simply be titled “Appendix”.

The following pages demonstrate techniques for inserting graphics and tables that are too wide to fit in a normal portrait page. There are a number of ways to place wide material on a page:

- Rotate a graphic on a normal portrait page using the Draw -> Rotate or Flip commands, and use a rotated text box for the caption.
- Use section breaks to create a landscape page within the normal portrait document. Remove the header containing the page number and use a rotated text box to place the page number in the appropriate location.
- In Word XP, a table can be pasted into the document using Paste Special, pasting the table as a Picture (Enhanced Metafile). The table can then be rotated like a graphic.

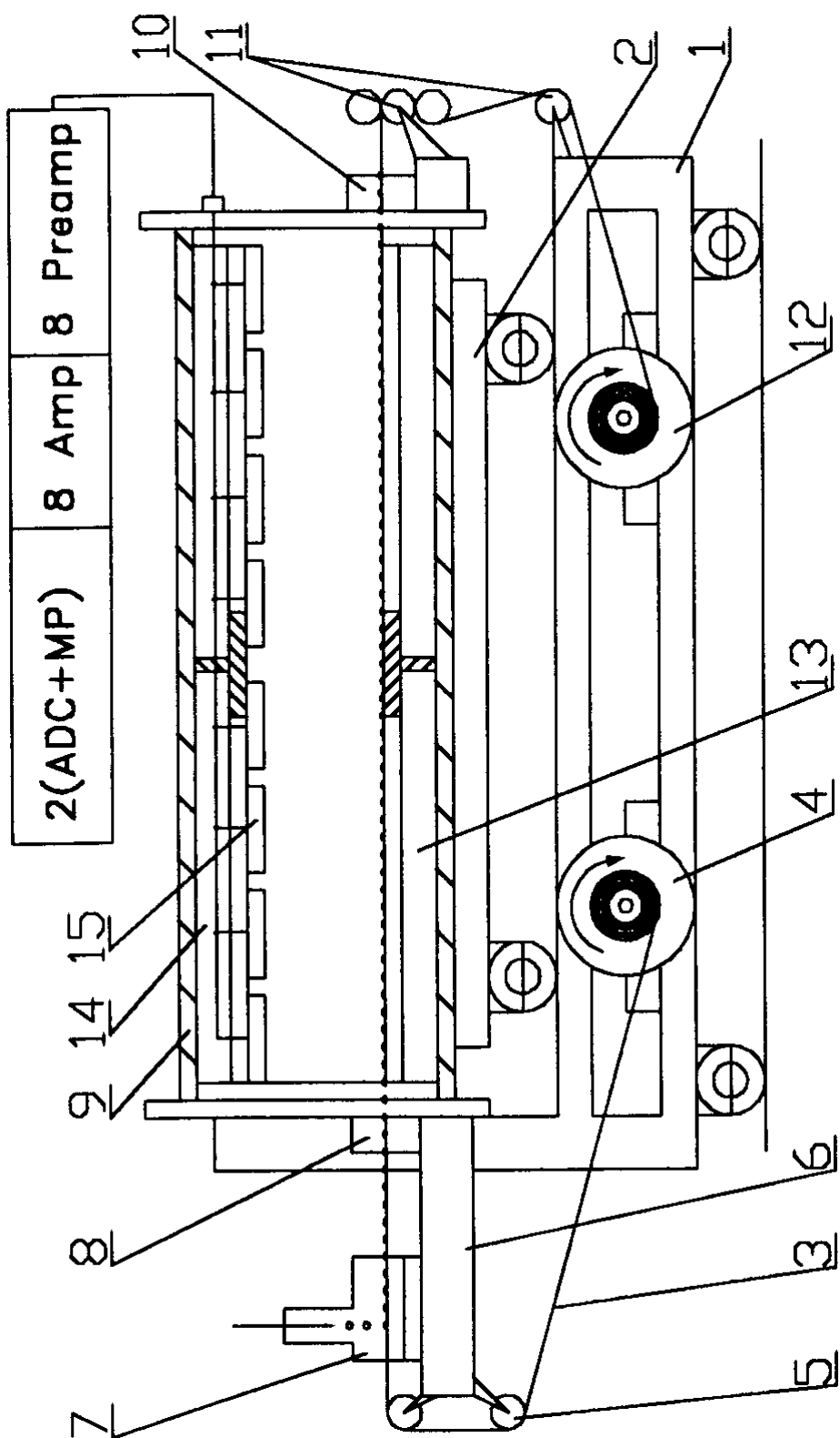

Figure 3. Detail of the preamplification unit

**Table 5. Software available in the 139 Durham labs in the early 2000s**

Description	Windows XP	Mac OS 9	Gratis	Sitelicensed
Analytical computation/visualization				Maple 6
Animation/Javascript editor	Adobe Imageready			
Animation/Javascript editor	Macromedia Fireworks			
CD burning software	Nero		Gnome Toaster, cdrecord	
	MS Windows			
Chat client	Messenger		EveryBuddy	
Database	Microsoft Access		Gaby, LEAP	Sun ADABAS
FTP client	WS_FTP LE	Fetch 4.0.1	ftp, gftp	
Image editor	Adobe Photoshop	Adobe Photoshop	GIMP	
Internet collaboration tool	Microsoft Netmeeting		gnomemeeting	
Kerberized telnet client	HostExplorer Telnet	BetterTelnet	ISL telnet	
Mathematical computing/visualization				Matlab 6
Page layout tool	Adobe Pagemaker		Scribus	
PDF generator	Adobe Acrobat	Adobe Acrobat	GhostScript	
PDF reader	Adobe Acrobat Reader	Adobe Acrobat Reader	Acroread	
Presentation graphics	Microsoft PowerPoint	Microsoft Powerpoint	OOoImpress	StarImpress
Spreadsheet	Microsoft Excel	Microsoft Excel	OOoCalc	StarCalc
				JMP (avail
Statistics package	JMP 5.0.1	JMP 5.0.1	R	2003)
Statistics package	SAS 8.2			
Vector graphics editor	Macromedia Freehand		ImPress	
Video editor	Adobe Premiere	iMovie	Kino	
Flash design tool	Macromedia Flash	Macromedia Flash		
Flash playback tool	Flash Player	Flash Player	Flash Player	

**Table 6. Software available in the 139 Durham labs in the early 2000s**

Description	Windows XP	Mac OS 9	Gratis	Sitelicensed
Analytical computation/visualization				Maple 6
Animation/JavaScript editor	Adobe Imageready			
Animation/JavaScript editor	Macromedia Fireworks			
CD burning software	Nero		Gnome Toaster, cdrecord	
Chat client	MS Windows		EveryBuddy	
Database	Messenger		Gaby, LEAP	Sun ADABA!
FTP client	Microsoft Access	Fetch 4.0.1	ftp, gftp	
Image editor	WS_FTP LE	Adobe Photoshop	GIMP	
Internet collaboration tool	Adobe Photoshop		gnomemeeting	
Kerberized telnet client	Microsoft Netmeeting	BetterTelnet	ISL telnet	
Mathematical computing/visualization	HostExplorer Telnet			Matlab 6
Page layout tool	Adobe Pagemaker		Scribus	
PDF generator	Adobe Acrobat	Adobe Acrobat	GhostScript	
PDF reader	Adobe Acrobat Reader	Adobe Acrobat Reader	Acroread	
Presentation graphics	Microsoft PowerPoint	Microsoft PowerPoint	OOoImpress	StarImpress
Spreadsheet	Microsoft Excel	Microsoft Excel	OOoCalc	StarCalc
Statistics package	JMP 5.0.1	JMP 5.0.1	R	JMP (avail 2003)
Statistics package	SAS 8.2			
Vector graphics editor	Macromedia Freehand		ImPress	
Video editor	Adobe Premiere	iMovie	Kino	
Flash design tool	Macromedia Flash	Macromedia Flash		
Flash playback tool	Flash Player	Flash Player	Flash Player	
Web browser	MS Internet Explorer 6.0	MS Internet Explorer 5.1	Mozilla 1.2.1	
Web design tool	Adobe GoLive	Adobe GoLive	Quanta	
Word processor	Microsoft Word	Microsoft Word	OOoWriter	StarWriter

## **APPENDIX B. STATISTICAL RESULTS**

An appendix is used for materials that do not pertain directly to, but are relevant to the main text. Examples include survey instruments, additional data, computer printouts, details of a procedure or analysis, or a relevant research paper. The material in an appendix may appear in a different font or use different spacing from the main text of the thesis, but you must try to comply with the margin limitations of the rest of the text and the page number should use the same font and position. Use photoreduction or equivalent resizing if necessary.

Supplemental statistics appear here.

More information here.

**BIBLIOGRAPHY**

Allen, B. S. (1984). System-assigned learning strategies and CBI. *Journal of Instructional Computing Research*, 1(1), 3–18.

Bruner, J. (1960). *The process of education*. New York: Random House.

Cox, S. R. (1974). Computer-assisted instruction and student performance in macroeconomic principles. *The Journal of Economic Education*, 6(1), 29–37.

## **ACKNOWLEDGEMENTS**

I would like to take this opportunity to express my thanks to those who helped me with various aspects of conducting research and the writing of this thesis. First and foremost, I thank Dr. Susan D. Ross for her guidance, patience and support throughout this research and the writing of this thesis. Her insights and words of encouragement have often inspired me and renewed my hopes for completing my graduate education. I would also like to thank my committee members for their efforts and contributions to this work: Dr. August Tanner and Dr. Lewis Hargrave. I would additionally like to thank Dr. Tanner for his guidance throughout the initial stages of my graduate career and Dr. Hargrave for his inspirational teaching style.